

Dimensions: mm (In.)

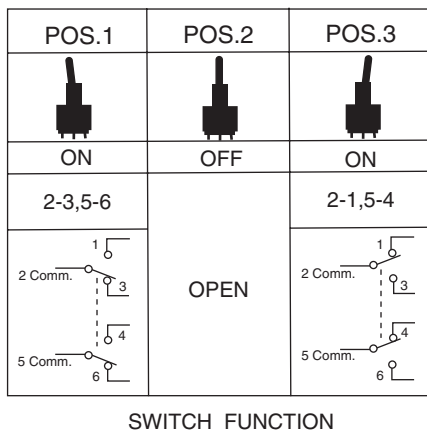
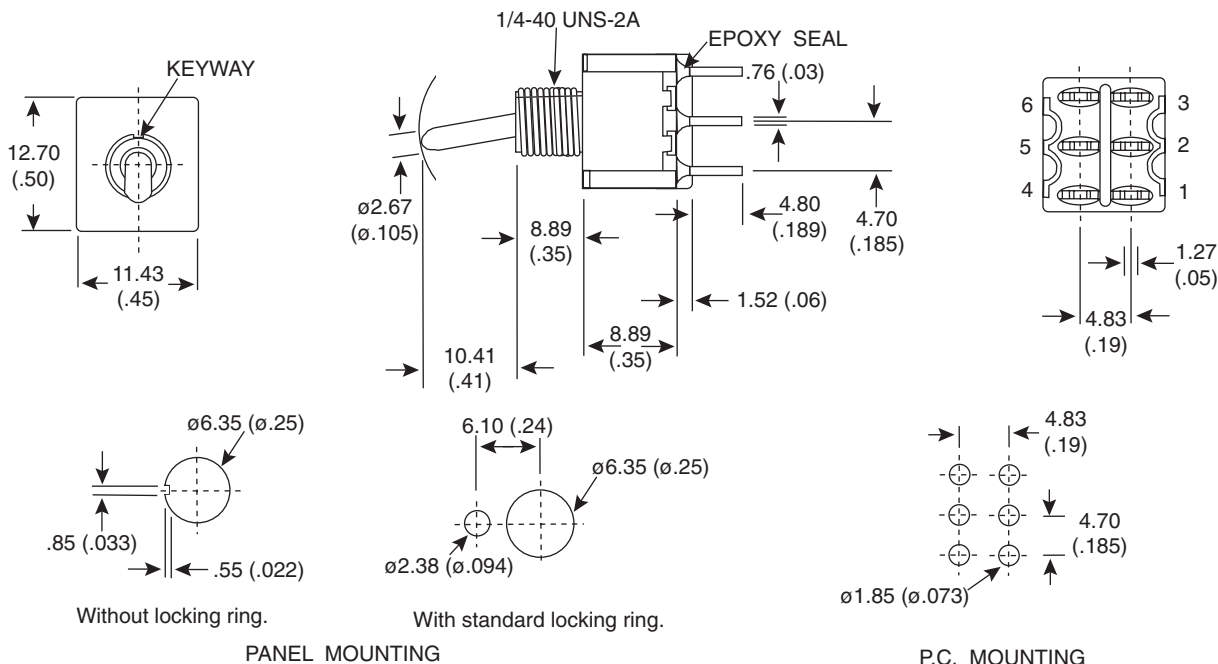

Electrical Specifications:

- Electrical Life: 40,000 make-and-break cycles at full load
- Contact Resistance: 10mΩ max. initial @ 2-4VDC 100mA
- Insulation Resistance: 1,000MΩ min.
- Dielectric Strength: 1,000 V RMS @ sea level
- Rating: 2A / 250VAC; 5A / 120VA or 28VDC

Mechanical Specifications:

- Operating Temperature: -30° C to +85° C

Note:

- RoHS Compliant by Exemption

Materials:

- Case: Diallyl phthalate (DAP)
- Actuator: Brass, chrome plated
- Bushing: Brass, nickel plated
- Housing: Stainless Steel
- Terminal / Contact: Silver or Gold plated

Toggle Switch
108-1MD3T1B1M2QE-EVX

